

Fast and Accurate Pre-conditioning Method for Li-on Battery Cell-balancing Tests

Nguyen-Anh Nguyen¹ and Sung-Jin Choi*

Department of Electrical, Electronic and Computer Engineering, University of Ulsan, South Korea

¹nanh1995@gmail.com, *sjchoi@ulsan.ac.kr

ABSTRACT

In battery system testing, achieving accurate initial conditions is crucial. A cyclor is often employed to ensure a precise initial state of charge (SOC) between experiments. Additionally, maintaining consistent setup times is essential. However, conventional one-at-a-time-cell preconditioning suffers from complexity, time consumption, and high machinery costs. To address these limitations, this paper first introduces an innovative scheme that reverses the cell balancing to achieve the predefined targets for each cell: de-balancing. The proposed algorithm is validated using PSIM simulation software for 20 series-connected battery cell models. The simulation results demonstrate superior de-balancing performance with minimal adjustment errors and optimal operational time.

Keywords: Bidirectional, charger-transfer, de-balance.

1. INTRODUCTION

Energy storage systems are the cornerstone of electric vehicles (EVs) and battery energy storage systems (BESSs), including over 50% of their total cost [1]. Therefore, ensuring battery quality before deployment is critical. Establishing initial conditions is particularly essential for accurate battery quality testing. The preconditioning for Li-ion battery cell-balancing tests is crucial to ensure uniformity among cells, thereby yielding accurate and reliable results [2]. In the conventional method [3], the preconditioning setup segment includes 3 steps:

Step 1: Lithium-ion battery (LiB) cells are disassembled and fully charged in the chamber.

Step 2: The cells rest for 1 hour before proceeding to the next step.

Step 3: Cells are discharged by a small constant current, reducing the SOC of the cell until reaching the targets. The battery samples are given a 1-hour resting period before being re-installed into the system for test.

However, in the conventional method, this approach suffers from drawbacks such as complexity in implementation, time-consuming processes, and substantial machinery costs. To address this challenge, this paper proposes a rapid and precise preconditioning method for lithium-ion battery tests. The preconditioning of the SOC of the cell is the reverse process of balancing and thus can be called a de-balancing process. This system leverages the equalizer circuit [4], referred to as the de-balancer in this study, to execute the de-balancing process for each cell without dismantling the system. The proposed de-balancing method is validated using PSIM for a configuration of 20 series-connected battery cells.

2. PROPOSED METHOD

The configuration of the proposed system utilizes an isolated bidirectional converter, which is linked to the battery string via a switch matrix, as illustrated in Fig. 1.

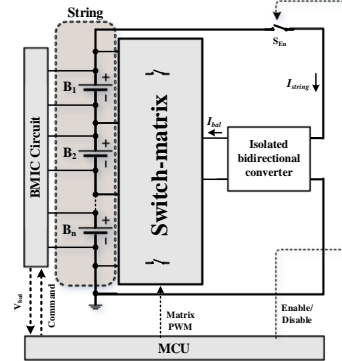

Fig. 1: Configuration of the system

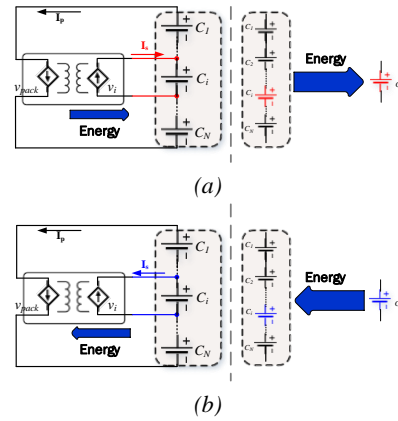

Fig. 2: Energy flow strategies: (a) string to cell (S2C), (b) cell to string (C2S)

This bidirectional de-balancing mechanism is deployed to efficiently execute SOC de-balancing among the cells. By using the bidirectional converter, energy is either transferred from the battery string to the cells or from the cells to the string, respectively. Notably, the converter is designated once for each cell, thus the number of de-balancing steps directly corresponds to the number of cells within the string. While the battery cell is charged/ discharged by a constant current, I_s , the whole battery string is discharged/charged by a corresponding constant current, I_p , as shown in Fig. 2.

According to [4], the amount of SOC change after time t is determined as

$$SOC(t) - SOC(t_0) = \frac{(t - t_0)I}{Q_{nom}} \quad (1)$$

where $SOC(t)$ is the SOC of a cell at t , t_0 represents the initial time of the process, Q_{nom} is the nominal capacity of one cell and is regarded as identical for all cells; I is the constant charging current of cells.

The operating time for each cell, t_i , is expressed as

$$t_i = \frac{[SOC_{target,i} - SOC_{init} + SOC_L]Q_{nom} + SUM \times I_p}{I_s} \quad (2)$$

where i is the index of cells in the battery string, $SOC_{target,i}$ is

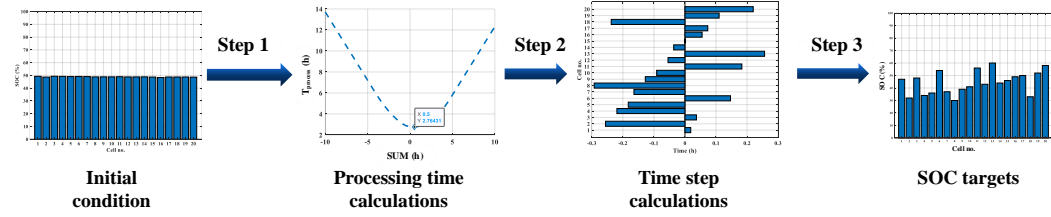

Fig. 3: De-balancing workflow

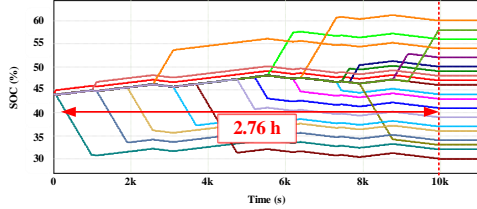
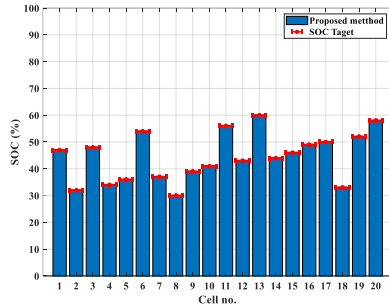
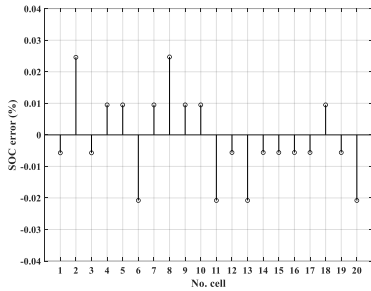

Fig. 4: Time trend of SOC of the cell by the proposed method.



(a)



(b)

Fig. 5: Simulation results: (a) final SOC profiles; (b) SOC de-balancing errors.

the target SOC of the i -th cell, SOC_{init} is the initial SOC of the battery pack, SOC_L is the average loss of one cell during the process and SUM is the weighting factor summation of the step time. Finally, the total time of the whole process, $T_{process}$, expressed as

$$T_{process} = \sum_{i=1}^n |t_i|. \quad (3)$$

By selecting the value of SUM , it becomes feasible to optimize and minimize the total operating time. Fig. 3 illustrates the de-balancing procedure, encompassing three steps:

- Step 1: Battery management integrated chip (BMIC) measures and estimates the initial condition of battery cells.
- Step 2: Total operating time is analyzed and optimized by choosing the weighting factor, SUM .
- Step 3: Step time of each cell is calculated based on (2). Therefore, the SOC levels are adjusted as the cell index.

Table 1: System configuration

Type	20S1P (18650-3.6V/2.9Ah)
SOC initial [%]	45
SOC targets [%]	47, 32, 48, 34, 36, 54, 37, 30, 39, 41, 56, 43, 60, 44, 46, 49, 50, 33, 52, 58
$ I_{bal} $ [A]	1.5
$ I_p $ [A]	0.1

After the end of the operation of the de-balancer, the SOC levels of the cells are set at the target SOC points.

3. SIMULATION RESULT

To validate the proposed method, simulations are conducted using PSIM simulation software for a battery string comprising 20 cells (18650, 3.6V/2900mA). The proposed method is implemented as outlined in Table 1. The initial state-of-charge (SOC) levels of the cells are set at 45%, while SOC targets are set as in Table 1.

Fig. 4 illustrates that the proposed method can make the cell reach the SOC targets after de-balancing process. Additionally, the proposed method only takes 2.76 hours to complete the process. Fig. 5(a) shows the accuracy compared to the SOC targets. In Fig. 5(b), the SOC de-balancing errors indicate that the proposed method achieved high accuracy, with errors consistently below 0.1%.

4. CONCLUSION

This paper proposes the fast and accurate de-balancing method for Li-ion battery strings. The proposed method efficiently executes SOC de-balancing among the cells. The SOC levels of the cells can be adjusted to the target levels. The total operating time is only 2.76 hours and the SOC errors are less than 0.1%. Since the proposed algorithm is computation-efficient, it can be implemented by any simple embedded system-based BMS.

ACKNOWLEDGMENTS

This work was supported by Regional Innovation Strategy (RIS) through the National Research Foundation of Korea (NRF) funded by the Ministry of Education (MOE) (2021RIS-003).

REFERENCE

- [1] Fu, Ran, Timothy W. Remo, and Robert M. Margolis. *2018 US utility-scale photovoltaics-plus-energy storage system costs benchmark*. No. NREL/TP-6A20-71714. National Renewable Energy Lab.(NREL), Golden, CO (United States), 2018.
- [2] Brodd, Ralph J., Akiya Kozawa, and Masaki Yoshio. *Lithium-Ion Batteries: Science and Technologies*. Springer, 2009.
- [3] Soares, Rudi, et al. "An experimental setup with alternating current capability for evaluating large lithium-ion battery cells." *Batteries* 4.3 (2018): 38.
- [4] Nguyen, Nguyen-Anh, Phuong-Ha La, and Sung-Jin Choi. "Coordinated operation algorithm of string-chargers and cell-equalizers for SOC adjustment in second-life batteries." *Journal of Power Electronics* 22.1 (2022): 105-115.